

Pluto 3 Cargo Pump



Market

The Pluto 3 is a precision, internal bearing, positive displacement, lobe type cargo pump specifically designed for the loading and discharge of hydrocarbon (oil) type products (non-flammable, with lubricating properties) in the oil, fuel and lubrication industries.



Specification

General Design

Robust build with twin tri-lobe rotors supported by bearing/sideplate arrangements at either end with the bearings situated in and lubricated by the liquid being pumped so that no additional lubrication/maintenance is required.

The contactless rotors are synchronised by precision timing gears at each end of both rotors.

Mounting

The pump shape and size is ideal for mounting inside the chassis on virtually all vehicles, enabling low cost PTO driving where required.

The pump allows CW or ACW input drive rotation by swapping the relief valve to the other side of the unit. The pump can be mounted on any of its four sides to provide maximum mounting flexibility.

The Standard Package

The Pluto 3 is supplied for either CW or ACW drive rotation with a basic flange and mounting pack in 2 variations as follows:

1. Standard pump, standard mechanical seal with integral 5 or 7 bar relief valve setting. This build type is normally used with general hydrocarbon products including crude oil, diesel oil, gas oil, and lubricating oil.
2. Standard pump, Viton mechanical seal with integral 5 or 7 bar relief valve setting. This build type is intended for use on special solvents and some grades of kerosene.

Lobe Type Cargo Pumps

■ P3

PLUTO 3 LOBE TYPE CARGO PUMP

Dimensions

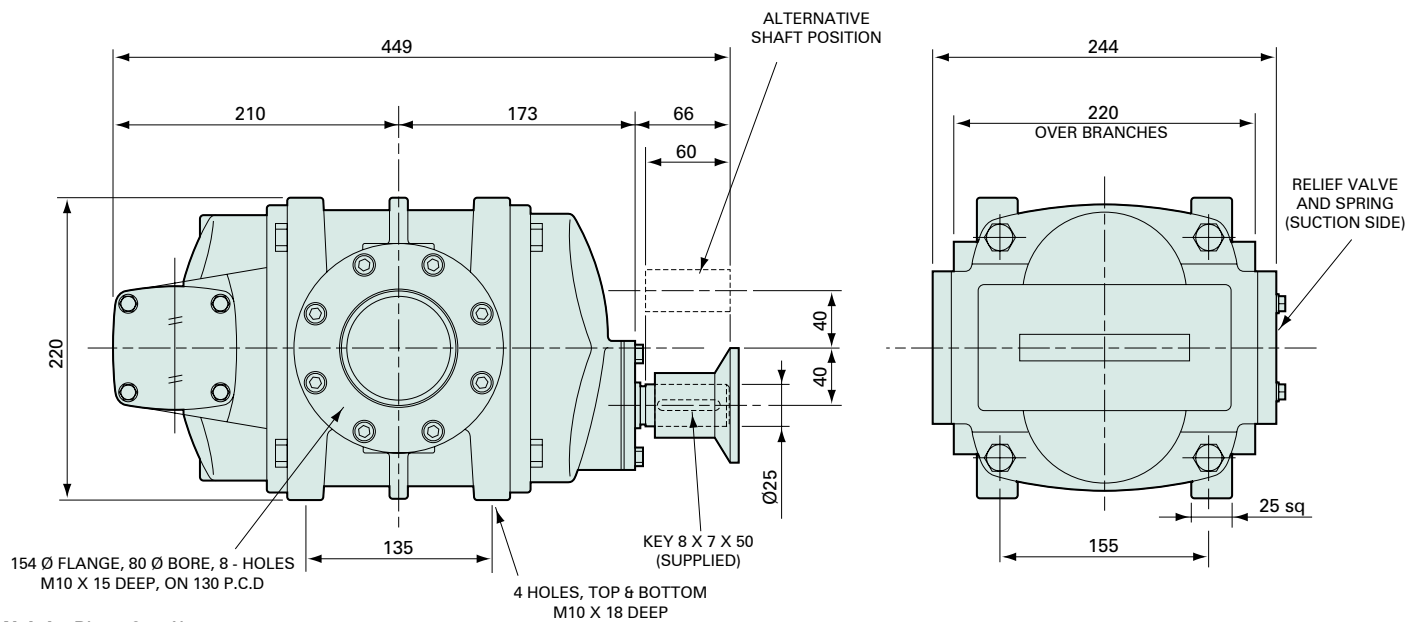

Weight Pluto 3: 51kg

Optional ancillaries

- Drive flange (various)
- Inlet strainers
- Reverse flow valves

Drive options

- Prop. shaft drive:** Direct from a vehicle PTO
- Hydraulic drive:** Several drives can be offered depending on the application
- Electric motor drive:** Packages on base frames
- Engine drive:** Packages on base frames

Performance

Showing flow and power performance at a viscosity of 5 cSt

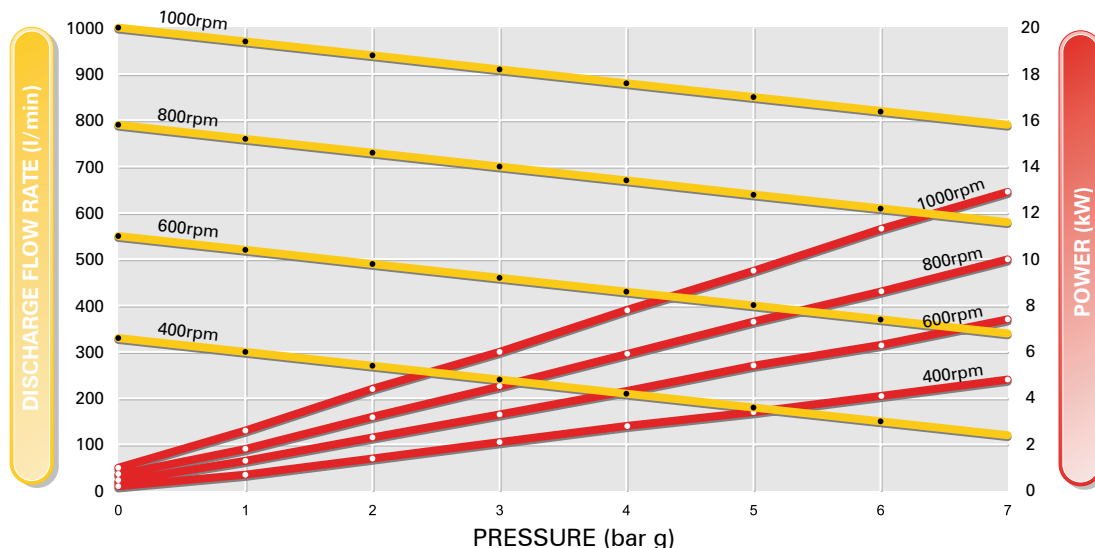

Liquid list: Generally non-toxic, non-flammable liquids with viscosities from a few centistokes (mm²/s) up to many thousand including lubricating oil, crude oil, gas oil, diesel oil, kerosene and other fuels.

CONTACT YOUR GARDNER DENVER REPRESENTATIVE

CONTACT HEAD OFFICE



PO Box 178, Springmill Street, Bradford, West Yorkshire, BD5 7YH, England

Tel: +44 (0) 1274 718100 Fax: +44 (0) 1274 718101

Sales: +44 (0) 1274 718160

Web: www.gardnerdenverproducts.com

e-mail: sales.gddrum@gardnerdenver.com